

THE PLATINUM PACKAGING GROUP

40 MODEL HORIZONTAL WRAPPER



- ◆ 90 PACKAGES PER MINUTE
- ◆ COMPACT DESIGN
- ◆ FLEXIBLE PACKAGE SIZE RANGE
- ◆ EASY MAINTENANCE

Platinum's **40 Model** Horizontal Wrapper is designed for operating speeds of up to 90 packages per minute. The compact design of the **40 Model** saves valuable floor space while offering 4.5 feet of unobstructed product feeding space.

An **adjustable former** permits fast size changeover to accommodate a variety of products, saving the cost of additional fixed formers for different product sizes. Touch screen electronic controls provide fast and precise product changeover with 15 programmable product set-ups.

No tools are required for changeovers. The unique EZ-SET end crimper phasing device allows the operator to position the crimper between the products during initial setup, then easily fine tune the setting ... while the machine is running!

The **40 Model** is well suited for using a variety of roll stock materials, printed or clear films. It is surprisingly affordable in price and so versatile, it's ideal for a wide variety of confection, bakery, snack food, pharmaceutical and general industrial applications.

Platinum 40 Model Horizontal Wrapper

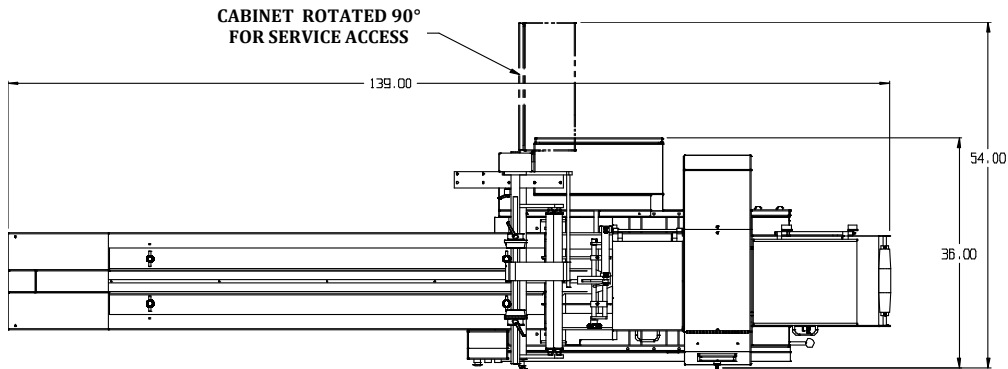

SPECIFICATIONS

- **Machine Size**
Length – 139"
Width – 36"
Height – 62"
- **Infeed Conveyor**
Length – 92"
Feed Space – 54"
Height Above Floor – 37"
- **Wrapping Material**
Maximum Parent Roll Diameter – 13"
Roll Width – 20"
1 Parent Roll
- **Fin Seal Assembly** (Length Seal)
First Set – Sealing
Second Set - Pulling
- **End Crimper** (Cross Seal)
1 – up x 8" wide standard ■ Optional up to 10"
- **Product Discharge**
Conveyor, 24" long
- **Touch Screen for Machine Controls**
- **Product Flow**
Left to right, facing the control panel
- **Painted and Stainless Steel Finish**

- **Maximum Package Size**
(Cannot be tolerated simultaneously)
Length – 16"
Width – 7"
Height – 2 5/8" Standard
3 1/2" Optional
- **Electrical**
1/2 HP AC Drive Motor
230 V, 3 PH, 60 H
- **Maximum Mechanical Speed**
90 Cycles Per Minute
- **Weight**
900 lbs.

OPTIONAL EQUIPMENT

- Overload Clutch on Crimpers
- Expanded Spare Parts Kit
- Electric Eye

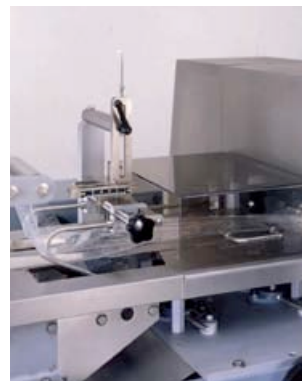

ADJUSTABLE FORMER

Quick size changeover for different products

Specifications subject to change without notice.