

THE PLATINUM PACKAGING GROUP

PLAT *Machinery* Free Standing Fillers

DUAL DEPOSITOR SERIES

Double your production. Produce on dual lane systems

PPG has the perfect depositors for dual lane production systems. Based on the world's best depositors, the Dual depositors allow you to produce more in less time.

The Dual Depositor Series is available in 3 options:

- Dual Compact
- Dual PRO 1000i
- Dual PRO 2000i

Benefits:

- Accurate portion control from each port
- Tool free, quick cleaning and change-over design
- Less parts to setup, clean and maintain compared to using two separate depositors
- Only one hopper to fill
- Independent depositors with individual speed and volume controls
- Independent depositor signaling depending on application

Features:

- Height adjustable, heavy duty stainless steel frame options
- Can be fitted with over 100 PPG nozzles and accessories
- Fully wash down. All food contact parts are dishwasher safe
- Foot operated starter switch (step once for single deposit or hold down for repeated deposit)
- Rectangular hopper, 15 US gallon (57 liter), with option to divide for split product depositing

System Includes:

- Foot pedal
- Quick start guide
- Spare parts kit *Nozzles sold separately*



DUAL DEPOSITOR SERIES

Double your production. Produce on dual lane systems



Custom Low Level version



Individual deposit size and deposit speed adjustments



Custom hopper with stirrers



Ideal for integration dual lane tray sealing and form-fill lines

Product Cylinder Sizer	Deposit Volume (fl oz)	
DUAL Depositor Series	Min	Max
Dual Compact (1", 1.5", 2", 2.5" 3")	0.25 oz (7 ml)	18 oz (530 ml)
Dual Pro 1000i (1", 1.5", 2.5", 3")	0.5 oz (14 ml)	36 oz (1060 ml)
Dual Pro 2000i (1.5", 2.5", 4", 5")	1.3 oz (40 ml)	93 oz (2750 ml)

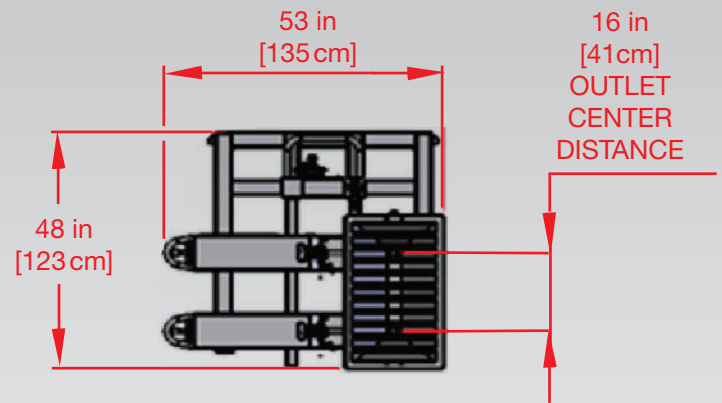

Specifications



SPEED

to 140 cycles
(Pro 2000i 110
cycles) per
minute

based 20%
volume and
product
consistency



PARTICLE SIZE

**Compact and
Pro 1000i:**
Up to 3/4 cube
(19 mm)

Pro 2000i:
Up to 1.5"
cube
(38 mm)



SHIPPING

Dimensions:
L x W x H
70 x 35 x 62"
(175 x 90 x 155 cm)

Weight:
550 lbs
(250 kg)



POWER

Air:
8 CFM @ 80 PSI

226 L/ min
@ 5.5 bar

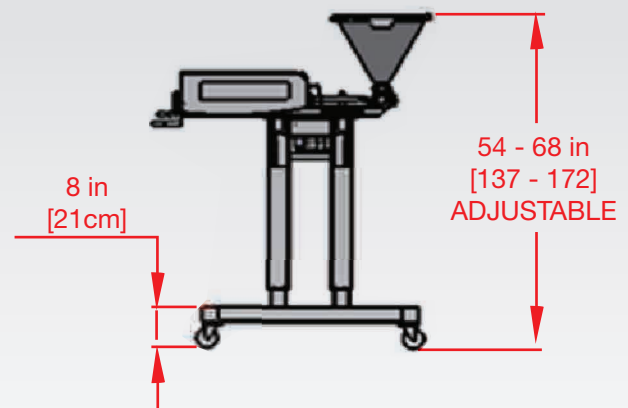

Layout drawing shows Dual 1000i Depositor with standard stand

Note: Equipment is designed to run at the quoted speed and is depending on operator efficiency, skill, deposit size and product consistency.

DUAL DEPOSITOR SERIES

Product Configurator

Item	Select	Notes
Base Machine		
Dual Compact		
Dual I000i		
Dual 2000i		
Low Level		
Hoppers		
Standard rectangular hopper		
Individual, connected conical hoppers (for use with Stirrers)		
Product Cylinder Kits Compact and I000i		
(Hot kits for product Temperatures 140-180 dg F)		
1"		
1.5"		
2.5"		
3"		
Product Cylinder Kits Compact and 2000i		
(Hot kits for product Temperatures 140-180 dg F)		
1.5"		
2.5"		
4"		
5"		
Safe-T-Valves / Rotary Valves		
Standard		
Hot		

Item	Select	Notes
Attachment - Fixed Nozzles		
Drip Free Nozzle 1"		
Spot Depositor Kit		
Drip Free Nozzle 1.5"		
Diving Nozzle 1.5"		
Diving Nozzle 2.75"		
Accessories		
Foot Pedal		
Photo Sensors		
Depositor Locating Bracket		
Hopper Stopper		
Preventative Maintenance Kit		

THE PLATINUM PACKAGING GROUP

tel: (562) 630-6700

7627 Somerset Blvd., Paramount, CA 90723

TO PLACE ORDERS:
sales@platinumpkggroup.com

FOR MORE INFORMATION:
www.platinumpkggroup.com

QUESTIONS:
information@platinumpkggroup.com