

# THE PLATINUM PACKAGING GROUP

## PLAT**Machinery** Free Standing Fillers

### PRO 1000si FOOD SERVICE

#### Recall recipes at the touch of a button

This heavy duty servo-controlled volumetric depositor is ideal for bakery and food production. The Pro 1000si FS can be used for clean depositing of various products, with or without chunks such as batters, fruit fillings, sauces, deli salads, soups, and more. The Pro 1000si FS features angled surface covers to eliminate pooling of water and food particles and a pneumatic control system intended to work in extreme temperatures.

#### Benefits:

- Larger depositing range than pneumatic depositors
- Can produce very small accurate deposits
- Programmable volume and speed - reduces the time spent to set up and change-over
- Programmable pre-charge, suck back and reload speed for optimum control over densities
- Standalone machine or integrate into an automated production system
- Allows automated depositing systems to

#### Features:

- Now available with Unifiller+ in select markets
- PLC control system with color touch screen enclosed within a wash down stainless steel control panel
- 6 programmable modes for depositing, spreading, liquid deposits and multi shots
- Electronic recipe storage for 100 recipes
- Cycle counter and total deposit counter
- Heavy duty stainless steel construction with height adjustable frame supported on durable 5" castor heels

#### System Includes:

- Dozens of hand-held and block mounted nozzles to choose from
- 14 US gallon (52 liter) conical hopper or 10 US gallon cylindrical hopper with follower plate
- Selection of stirrers and heated hopper options
- Optional accessories for injecting or spraying
- Foot pedal

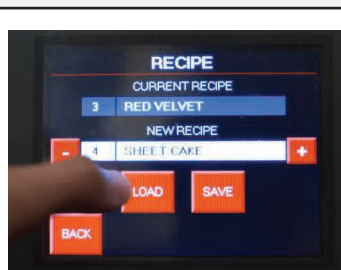

# PRO 1000si FOOD SERVICE

Recall recipes at the touch of a button

Standard Piston Depositor		Servo Depositor
Deposit Speed and Deposit Volume	Manual adjustment	Electronic, controlled via automated system
Minimum Deposit Size	15% of maximum deposit	5% of maximum deposit
Cycle Counter	No	Yes
Pre-Charge and suck-back	No	Yes, electronically adjustable
Recipe Storage	No	100 recipe storage capacity
Liquid deposit mode	No, liquids may splash	Slow start and finish to eliminate splashing
Spreading Applications	Ok	Excellent for spreading accurate portions
Check Weight compatibility	No	Yes, checkweigher can automatically adjust
Plant Network compatible	No	Statistical data (SPC) collect and reports.

## Product Cylinder Size

## Deposit Volume (fl oz)

	Min (5%)		Max	
	3"	1.8 oz	(55 ml)	36 oz
2.5"	1.25 oz	(36 ml)	25 oz	(725 ml)
2"	0.8 oz	(23 ml)	15 oz	(440 ml)
1.5"	0.5 oz	(12 ml)	8.0 oz	(240 ml)
1"	0.15 oz	(5 ml)	3.3 oz	(98 ml)

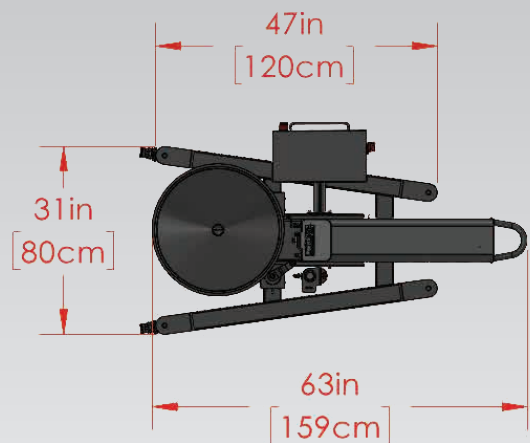

## Specifications



### Maximum production rates:

23 cycles/min @ 100% vol  
65 cycles/min @ 15% vol  
100 cycles/min @ 5% vol

Maximum attainable production rates. Actual production rates are dependent on product consistency, application, equipment setup and operator proficiency



### PARTICLE SIZE

Up to 3/4"  
cube (19 mm)



### ELECTRICAL

220 VAC, Single  
Phase, 10 A,  
50-60 Hz.



### AIR

2 cfm @ 80 psi  
57 L/min @ 5.5 bar

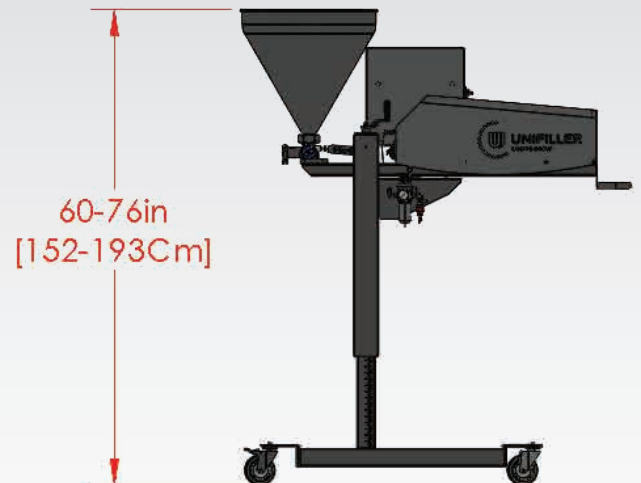

## SHIPPING INFO

### Dimensions: L x W x H

33x61x58" (84x155x148 cm)

Weight: 550lbs (250 kg)

NOTE: Equipment quoted is designed to run at the quoted speed and is dependent on operator efficiency, skill, deposit size and product consistency.

# PRO 1000si FOOD SERVICE

## Product Configurator

ITEM	PRICE	NOTES
<b>Base Machine</b>		
Standard		
<b>Hopper</b>		
14 US Gal Conical		
14 US Gal Conical Heated		
10 US Gal Cylindrical with Follower Plate		
<b>Product Cylinder Kits</b> (Hot kits for product Temperatures 140—180 dg F)		
1"		
1.5"		
2"		
2.5"		
3"		
<b>Safe-T-Valve</b>		
Hot		
Standard		
<b>Attachment—Handheld Nozzles</b>		
Hand Held Nozzle 1"		
Hand Held Nozzle 1.5"		
Hand Held Nozzle 1.5" Rotary Cutoff		

ITEM	PRICE	NOTES
<b>Attachment — Fixed Nozzles</b>		
Drip Free Nozzle 1"		
Spot Depositor Kit		
Drip Free Nozzle 1.5"		
Rotary Cut-Off Nozzle		
Twin Injection Nozzle ¼ Short		
Twin Injection Nozzle ¼ Long		
Twin Injection Nozzle ⅜ Short		
Twin Injection Nozzle ⅜ Long		
Diving Nozzle 1.5"		
Diving Nozzle 2.75"		
Cake Head		
Rosette Head		
<b>Attachment—Other</b>		
Horizontal Agitator		
Electric Stirrer		
<b>Accessories</b>		
Foot Pedal		
Work Table		
Tool Tray		
Photo Sensor		
Depositor Locating Bracket		
V-Block Centering Guide		
Hopper Stopper		
Rosette Head Twist Actuator		
Deluxe Spare parts kit		

### THE PLATINUM PACKAGING GROUP

tel: (562) 630-6700

7627 Somerset Blvd., Paramount, CA 90723

**TO PLACE ORDERS:**  
sales@platinumpkggroup.com

**FOR MORE INFORMATION:**  
www.platinumpkggroup.com

**QUESTIONS:**  
information@platinumpkggroup.com