

THE PLATINUM PACKAGING GROUP

PLAT **Machinery** Free Standing Fillers

MULTISTATION

Electronic Servo Multi Piston Depositing System

Traditional confectionary gearwheel depositors are used worldwide, and are known for performing very well but with limitations in production speed and type of products that they are able to work with.

In these applications the MultiStation M600 and M800 are the perfect alternate solution to traditional gearwheel confectionary depositors.

Clean deposit relatively viscous to liquid products with and without chunks such as batters, fruit fillings, sauces, delicate mousse fillings, salad dressings, soups, and dairy products.

Benefits:

- High speed production rates.
- Accurate portion control through each nozzle port.
- Smaller minimum portions than pneumatic depositors.
- Deposit chunks and particulate without damage.
- Gentle portioning with less damage on fragile, delicate products.

Features:

- Tool free quick change design 6 and 8 port configurations .
- Fits all types of pans and trays up to 18" (46 cm) wide.
- Servo driven (electronic) depositor.
- Integrated conveyor lift motion.
- Programmable touch screen color display with storage for 100 recipes and 7 selectable deposit modes.
- Minimal sanitation and maintenance requirements.
- Large hopper 11 US gal (42 liter) w/ safety cover

System Includes:

- Wide range of nozzles and manifolds to select from
- Optional 360 mechanism for round-cakes and twist rosettes
- Available configuration for injection
- Hopper with optional heater and/or agitator



MULTISTATION M600, M800



Custom Mode

Spread Mode

Chunky Fruit Filling

Éclair Mode

Machine Series	Product Cylinder Size	Deposit Volume (fl oz)			
		Min (5%)		Max	
M600	2" (5 cm)	0.4 oz	(13 ml)	8.7 oz	(255 ml)
M800	1.75" (4.5 cm)	0.3 oz	(10 ml)	6.7 oz	(200 ml)
Small Bore Pistons M600 / M800	1.25" (3.2 cm)	0.2 oz	(5 ml)	3.4 oz	(100 ml)

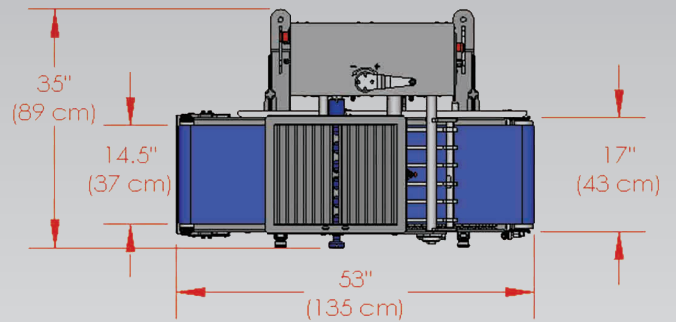

Specifications



SPEED

Up to 120 cycles / min

Based on 20% deposit volume and product consistency



PARTICLE SIZE

Up to 1/2" (13 mm) of soft fruit type fillings.



ELECTRICAL

220 VAC, Single Phase, 15 A, 50-60 Hz (non GFI supply)



AIR

4 CFM @ 80 psi (141.5 L/min @ 6.9 Bar)

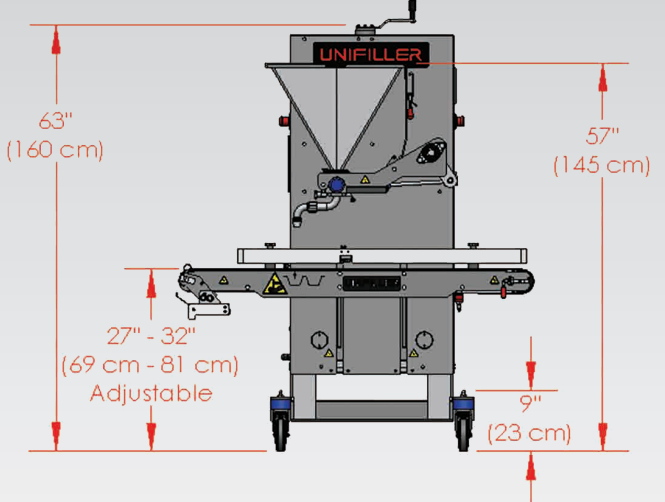

NOTE: Equipment quoted is designed to run at the quoted speed and is dependent on operator efficiency, skill, deposit size and



SHIPPING INFO

Dimensions: L x W x H

North America:

61 x 39 x 74" (155 x 99 x 188 cm)

Overseas:

58 x 41 x 63" (147 x 104 x 160 cm)

Weight: 800 lbs (360 kg)

THE PLATINUM PACKAGING GROUP

tel: (562) 630-6700

7627 Somerset Blvd., Paramount, CA 90723

TO PLACE ORDERS:
sales@platinumpkggroup.com

FOR MORE INFORMATION:
www.platinumpkggroup.com

QUESTIONS:
information@platinumpkggroup.com



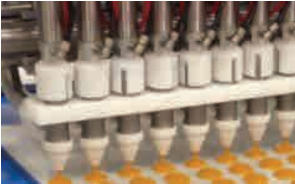

MULTISTATION M600, M800





Accessories

Accessory	Notes
Drip Free Nozzle Stabilizer 	<p>Keeps drip free nozzles located and aligned to a specific center to center.</p> <p>Manual center to center adjustment not required.</p>

Accessory	Notes
Conveyor Extension 	<p>Attached at the infeed of the conveyor, this helps when placing large pans.</p>

Attachments

Attachment	Notes
Heated Hopper 	<p>Use the MultiStation with warm products.</p>
Hopper Divider—Marble Cake 	<p>Split the outlets to draw product simultaneously from two chambers.</p> <p>Only available with “Direct from block” nozzles. Typically used for marble cake batter.</p>
Hopper Divider—Split 	<p>Split outlets for depositing two products at the same time side-by-side.</p>
Ring Nozzle 	<p>Deposit batter for mini Bundt cakes.</p>
Low Friction Valves 	<p>Designed specifically for extremely stiff or sticky products.</p>





Attachment	Notes
360 Nozzle Pneumatic 	<p>Apply twist rosette decorations on top of cupcakes.</p>
360 Nozzle Servo 	<p>Spread layers of icing on top of round cakes.</p>
Injection Tooling Kit 	<p>Inject muffins with creams and fillings.</p>
Flex Line Production Systems 	<p>Combine MultiStations with conveyors, Single Piston depositors and Hopper Topper pumps to create flexible production systems.</p>

MULTISTATION M600, M800

Product Configurator

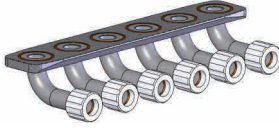
Item	Select	Notes
Base Machine		
MultiStation NA		
MultiStation EU		

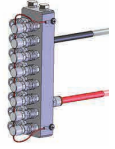
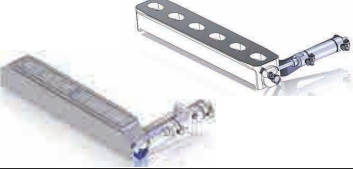
Item	Select	Notes
Product Cylinder Kits		
Hot kits required for product temperatures of 140 - 180 °F (60 – 82 °C)		
M 600 Standard (2" bore)		
M 600 Small Deposit (1.25" bore)		
M 800 Standard (1.75" bore)		
M 800 Small Deposit (1.25" bore)		

Select	Nozzle Setup	Nozzle Adapter and Fixed (Direct from Block) Nozzles	Adjustable Nozzle	Air Distribution Manifold
	Direct from Block Nozzle Plate		Not Applicable	Not Applicable
	Fixed Spout Nozzles with Tip Adapters		Not Applicable	Not Applicable
	Outlet Assembly with Spout Nozzles Minimal Center to Center: 1.7"			Not Applicable
	Outlet Assembly with Rotary Cutoff Nozzles Minimal Center to Center: 2.7"			
	Outlet Assembly with Drip Free Nozzle Minimal Center to Center: 1.75"			
	Rotary Manifold Nozzle Standard: 15.5" spread width Extended: 17.5" spread width		Not Applicable	
	Spreader Nozzle		Not Applicable	Not Applicable
	360 Nozzle Servo Standard attachment can accommodate: - 2 cakes up to 8.3" diameter - 3 cakes up to 4.2" diameter can be custom made with up to 6 outlets			Not Applicable