

THE PLATINUM PACKAGING GROUP

PLAT*Machinery* Free Standing Fillers

iPUMP

The Small, Economical Hopper Topper

Keep your hopper full and production running with the **iPump Transfer Pump**. With our gentle pumping technology, your product is quickly transferred without sacrificing quality.

• **BAKERY** • **FOOD**

Benefits:

- Continuous production
- No heavy lifting required
- Simulates hand scooping – gentle on your products
- Draws directly from mixing bowl or pail
- Tool free disassembly for quick and easy clean up
- Versatile – fits most pails and mixing bowls from 60 to 140 quarts
- Unique tilt mechanism allows for easy changing of mix-ing bowls.
- Small foot print and low height clearance
- Low air consumption

Features:

- Mobile all stainless steel construction frame
- All stainless steel 2" (50 mm) piston pump
- 5 foot flexible outlet hose with end "U" pipe to hook onto the rim of a hopper - 1.5 inch [38 mm] diameter
- Flow control to adjust pump speed for different types of products
- Product photo sensor allows you to automatically keep your hopper filled to maintain a consistent product level in the depositor hopper

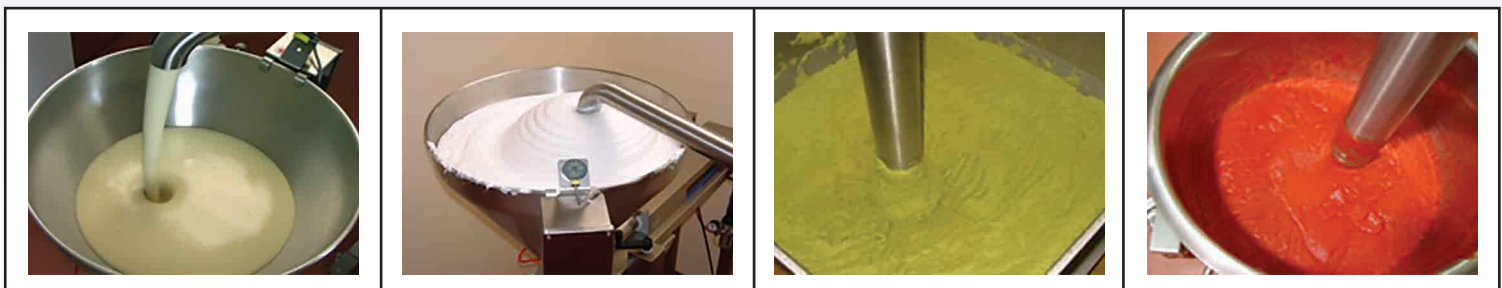

iPUMP

The Small, Economical Hopper Topper



A perfect fit with the MultiStation



Optional Photo Sensor monitors product level in the hopper and controls the pump

Specifications



SPEED

Up to 5.3 US gallons (20 L) per minute.



PARTICLE SIZE

Smooth products
Batters, fillings, custards, toppings, icings etc. with soft particulates up to ¼" (6 mm).



ELECTRICAL

Only required for optional hopper level sensor: 110 – 220 VAC, Single Phase, 1 A, 50-60 Hz



AIR

3 CFM @ 80 psi
(85 L/min @ 5.5 Bar)



SHIPPING INFO

Dimensions: L x W x H
42 x 38 x 75" (105 x 55 x 18 cm)

Weight: 250 lbs (113 kg)

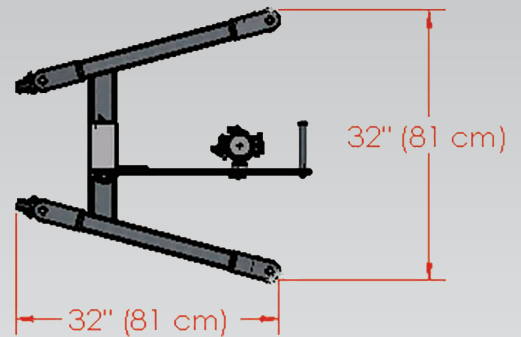

NOTE: Equipment quoted is designed to run at the quoted speed and is dependent on operator efficiency, skill, deposit size and product consistency.

THE PLATINUM PACKAGING GROUP

tel: (562) 630-6700

7627 Somerset Blvd., Paramount, CA 90723

TO PLACE ORDERS:
sales@platinumpkggroup.com

FOR MORE INFORMATION:
www.platinumpkggroup.com

QUESTIONS:
information@platinumpkggroup.com